

Manual Self-Contained Quarter-turn Emergency Shutdown(ESD) System



VTE® PressureGuard™

Reliable valve shutdown designed for remote locations where power source is unreliable or very costly



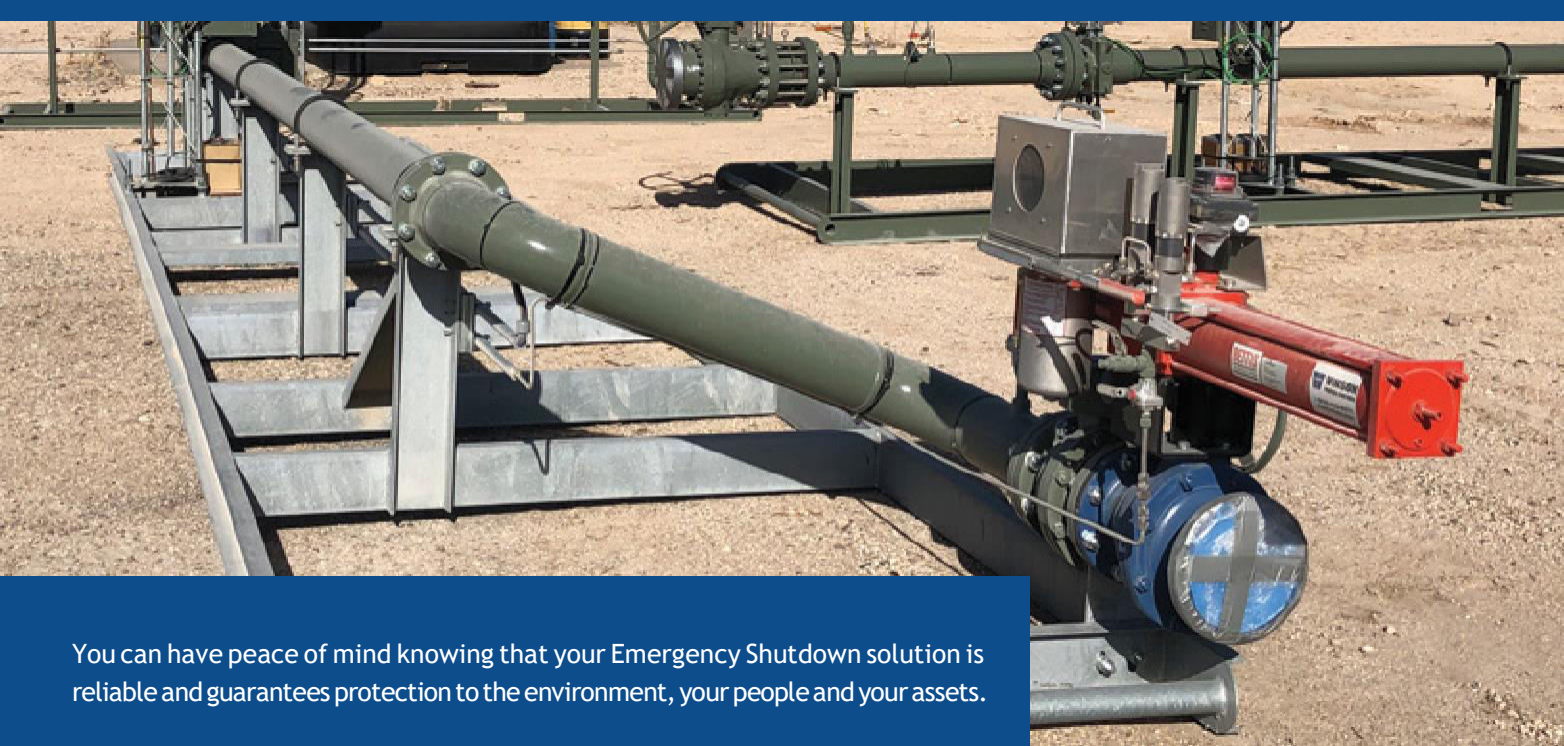

You can have peace of mind knowing that your Emergency Shutdown solution is reliable and guarantees protection to the environment, your people and your assets.

ESD Valve Actuation Solution



Scotch Yoke



The PressureGuard™ is a quarter-turn Self-Contained Hydraulic (SCH) system most often used in Emergency Shutdown (ESD), Overpressure Pipeline Protection (OPP), Process Shut Down (PSD), or any remote applications that require reliable valve shutdown capability.

The SCH is most often used whenever an external power source is either not available or not dependable. It does not require electrical power, flow line pressure, compressed air or gas for actuator power. Instead it uses its own clean, contaminant free hydraulic fluid generated by a simple and reliable mechanical hand pump.

This valve automation system is designed with safety, reliability and environmental preservation in mind, and is completely self-contained, mitigating any possible local contamination and therefore releasing no emissions.

Self-contained Hydraulic System

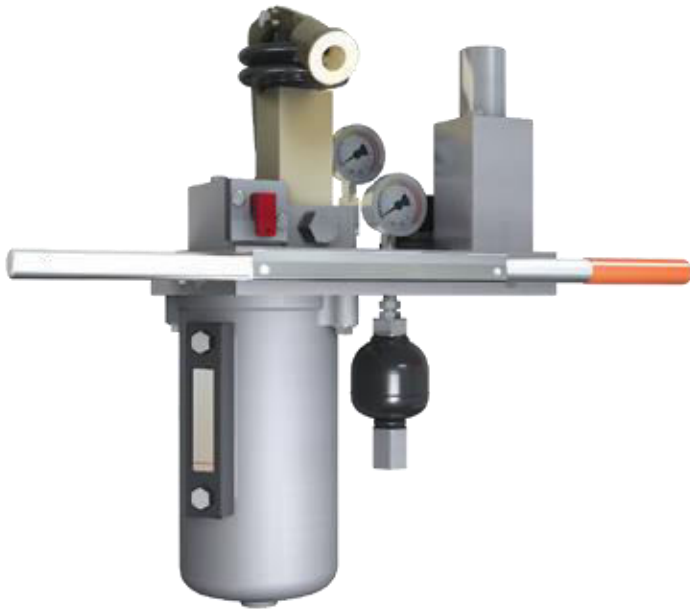

Overview

The PressureGuard™ system utilizes a common manual hydraulic hand pump to locally drive hydraulic fluid under pressure into the hydraulic cylinder of a spring-return actuator, thereby compressing the actuator's spring. The actuator will hold the valve in its normal operating position until a trip point/demand is reached, thereby allowing the compressed spring to move the valve to its fail-safe position.

Optional Features

VTE PressureGuard™ series emergency shutdown can be triggered by any one or a combination of the below.

Fire protection with a high temperature shutdown

The system can integrate a fusible plug(s) to initiate the valve shutdown during a fire. Three standard temperature options are available; 184° F / 84° C, 203° F/95° C and 255° F/124° C (others available upon request).

Shutdown by high and/or low pressure sensing

Utilizing high and/or low-pressure pilots, such as the Bettis™ Pressurematic, are installed on the flow line to automatically trigger the valve shutdown. The high and/or low pressure pilots initiate the valve shutdown when flow line pressure rises above or below set pressure thresholds, as would occur if the flow line pressure were blocked, ruptured or leaking.

Remote Shutdown by an ESD signal

The system can be remotely shut down by an ESD signal through energizing or de-energizing a solenoid valve integrated into the system.

Trigger by pressure drop rate (LineGuard™)

The system has an option to integrate the BETTIS LineGuard, which monitors pressure drop rate. If pressure drops or increases outside of the configured Major Event set point(s) for a certain period of time LineGuard would initiate the valve shutdown.

Ease of Use

Handpump



The hand pump transfers hydraulic fluid from the reservoir to the actuator and is common on all units. The pump features include a chrome plated ram, weatherproof boot and stainless steel hand pump handle. For ease of maintenance, a replaceable discharge filter and check valve is provided.

Hydraulic Reservoir



The hydraulic reservoir designed to be non-pressurized and sized to meet the systems requirements. It is equipped with a service friendly high/low level mark on the sight glass to avoid field guesswork, a fitted breather, houses a low pressure and high pressure relief valve for over-pressure protection, and suction screen at intake.

Manual Reset Valve

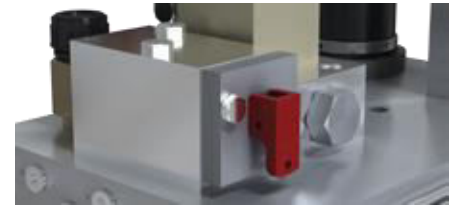

The manual reset valve is used to both arm the unit prior to pumping and as shutdown device. The manual reset valve allows the SCH system to be pressurized via the handpump as a manual override even when the shutdown trigger device is in the trip or failure position. When armed, the manual reset valve will remain in the horizontal position as a visual indicator (currently shown disarmed).

Safe Operation

Pressure Regulator



The pressure regulator is used to reduce the hydraulic pressure to allow the use of the low pressure control components in the control circuit.

Low Pressure Accumulator



The low pressure accumulator absorbs additional volume of the hydraulic fluid in the control system during significant temperature increases, negating pressure swings.

High Pressure Accumulator



The high pressure accumulator absorbs additional volume of the hydraulic fluid in the actuator during significant temperature increases, maintaining the proper actuator hydraulic pressure to prevent actuator spring stroke movement.

Corrosion Resistant

Breather



The weatherproof and corrosion resistant breather vents the reservoir to atmosphere.

Pressure Gauges

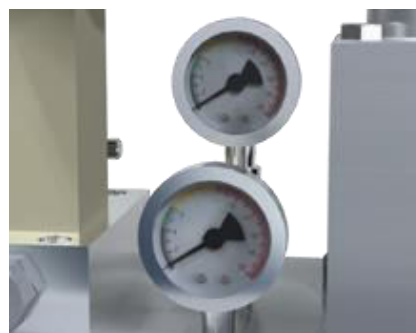

The stainless steel pressure gauges are an optional feature that displays the hydraulic pressure of the high pressure and low pressure circuits.

Manifold Cover Enclosure

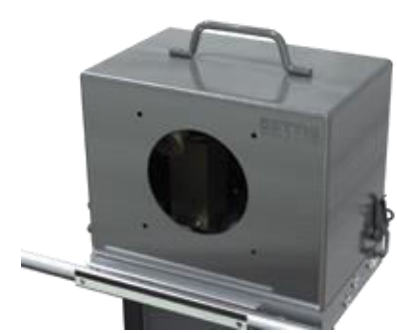

As an optional accessory, SCH's are available with weatherproof pad lockable control system enclosures to prevent unauthorized access.

Self-contained Hydraulic System - How It Works

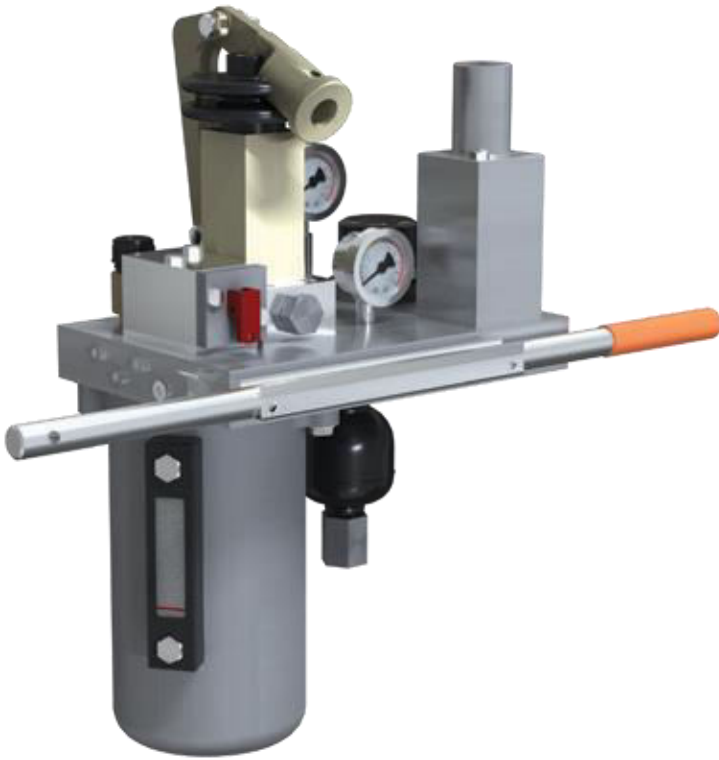

The Self-Contained Hydraulic (SCH) Emergency Shutdown (ESD) System provides reliable valve shutdown capability when an external power source is either not available or not dependable.

To operate:

- Manually arm the Reset Valve
Check to ensure that, if equipped, the Solenoid Valves or Pressure Pilots are in the proper operating mode
- Pump the Hand Pump to pressurize the SCH and actuator to the fully spring compressed position

The VTE PressureGuard™ is now armed to protect your equipment.

Basic Control Schematics

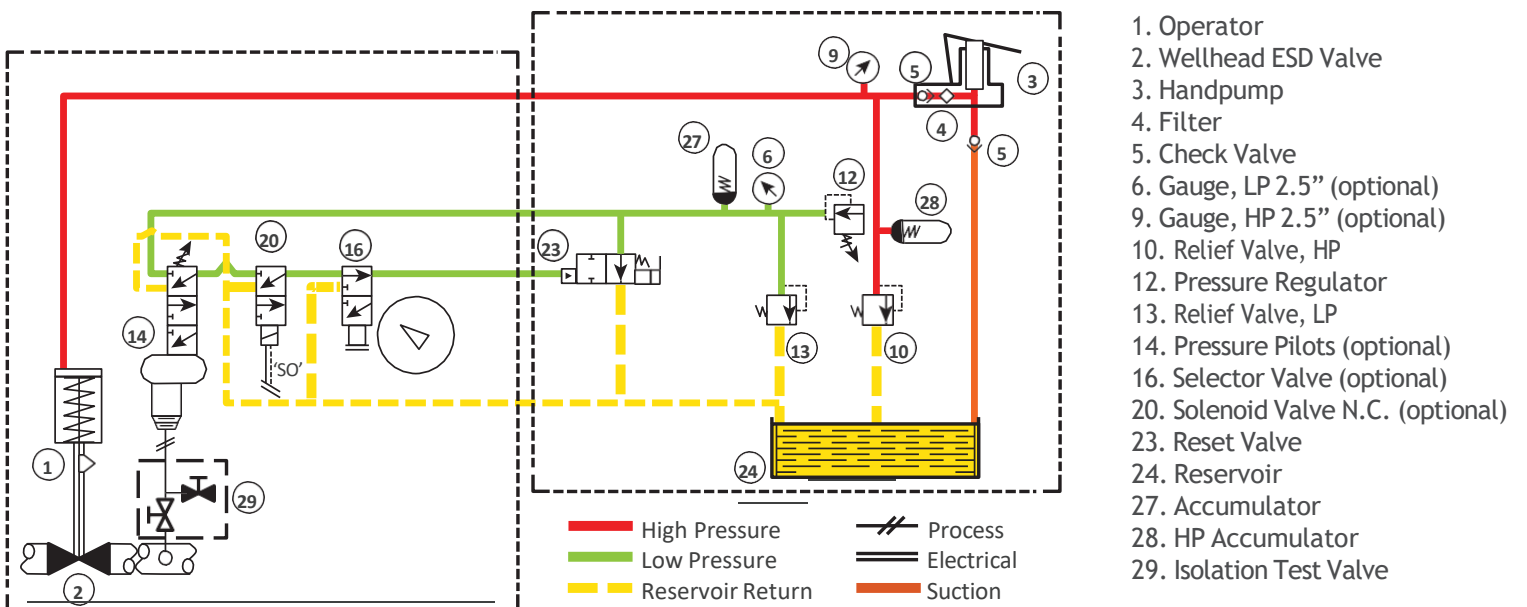

VTE® E-Series PressureGuard™

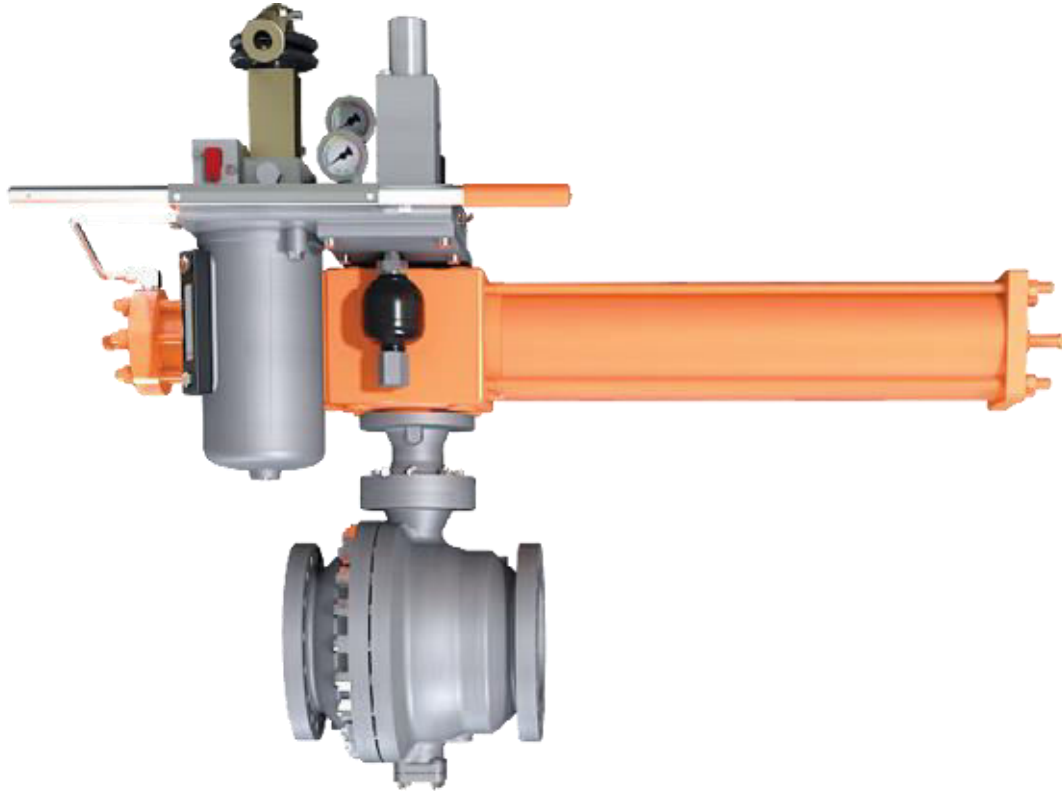

Construction

- Modular, with basic drive case/cylinder combinations to most economically suit field requirements
- Safe, reliable and field removable spring cartridges
- Tie rod cylinder construction for simplified maintenance
- Guaranteed torque output to ensure your safety function

Material

- Modular, with basic drive case/cylinder combinations to most economically suit field requirements
- Safe, reliable and field removable spring cartridges
- Tie rod cylinder construction for simplified maintenance
- Guaranteed torque output to ensure your safety function

Temperature

- Low temperature trim is standard: -50°F to +150°F
- High temperature trim is optional: -20°F to +225°F
- Consult factory for other temperature trims

Controls

- Local or remote control self-contained hydraulic system
- Complete control packages to suit specific applications

VTE® G-Series PressureGuard™

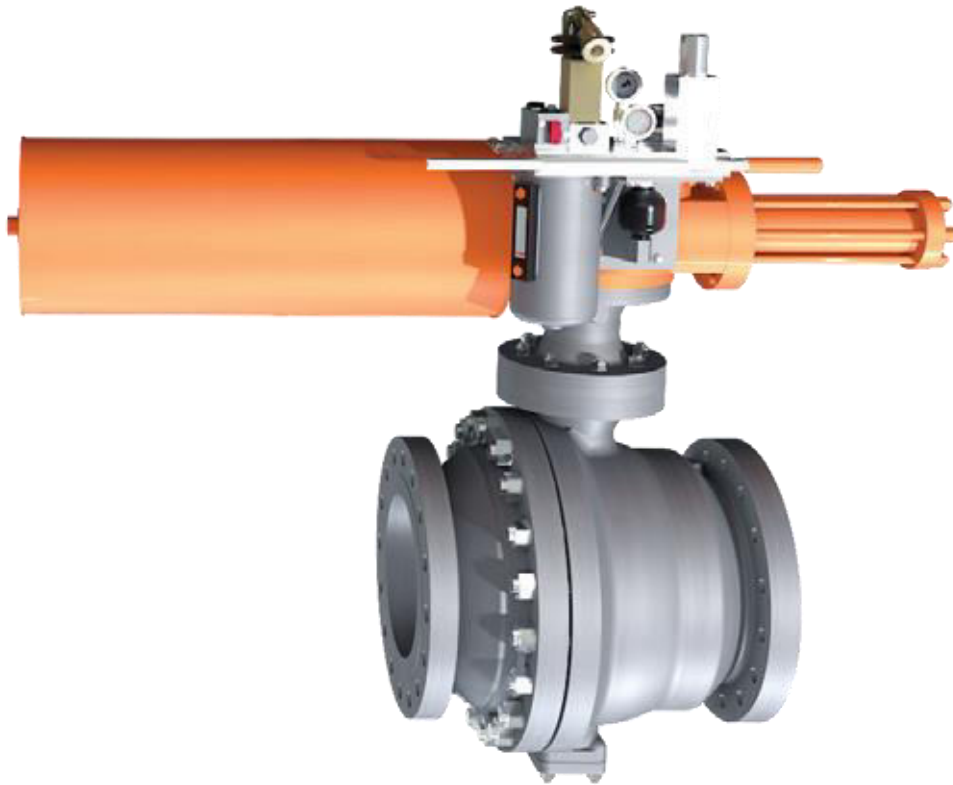

Construction

- Compact, optimize the center of gravity location. Significantly lighter and require less space than other actuators.
- Field serviceable drive, power, spring and override modules. The modules are removable, serviceable and interchangeable while mounted to the valve
- The Tension-Lok™ allows for the safe installation and removal of the spring module greatly reducing accidental release of the spring force
- Allowing for quick reversal of the fail-safe mode, while allowing the addition of overrides, accessories and other modules
- Water ingress IP66 and IP67M protected, has no gaskets and is totally O-ring sealed
- Superior surface finishes and self-lubricating bearings maximize input energy transfer directly to the valve stem. Efficiency is further enhanced by the outboarded spring, minimizing radial loads on the piston rod

Material

- Ductile iron and Alloy steel
- Corrosion resistant, with protective internal and external coatings, performs reliably in harsh environments.
- Two component polyurethane coating system

Controls

- Local or remote control self-contained hydraulic system
- Complete control packages to suit specific applications

Temperature

- Standard: -20°F to 200°F
- High temperature: 0°F to 350°F
- Low Temperature: -40°F to 150°F
- Consult factory for other temperature trims

Mitigate risks to people, environment,
and assets

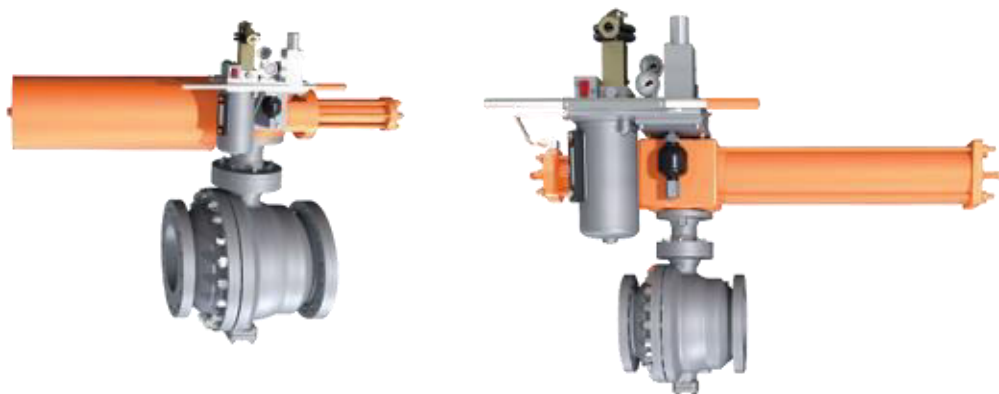

VAL TECHNOLOGY & ENGINEERING SDN. BHD.
No. 1, Lorong Teras Jaya 3, Taman Perindustrian Teras Jaya,
13400 Butterworth, Penang, Malaysia.
Tel: +604-333 4119 (Hunting) Fax: +604-333 4120
Email: sales@valtech.com.my URL: www.valtech.com.my