

**VTE®**

## **M2CP Electric Valve Actuators**

The strength of ductile iron with the agility of digital control



## A Heritage of Performance Reliability Built on Proven Technologies

M2CP actuators were introduced in 1979 as the Series 2000 electric valve actuator. Since that time, the model has added increasingly sophisticated control capabilities—but retained all the mechanical strengths that have established its three-decade record of reliability. As a result, many parts can interchange across the entire M2CP/Series 2000 range, and upgrades are remarkably easy to retrofit.

The robust mechanical design of the M2CP is evident in its ductile iron gear case, bronze worm gear, and heat-treated

alloy steel worm. Add the flexibility of modular control packages, plus an international sales & support network, and the result is an actuator to count on for the long term.

While the name has changed from Series 2000 to M2CP, BETTIS's uncompromising design and manufacturing standards have remained constant. These robust units are part of the same family of actuators that have proven themselves again and again across a wide range of applications in the world's most demanding environments.



*Current M2CP units evolved from proven technology—as shown by this actuator, still operating after more than 50 years at a water distribution and storage system in New York City.*



*Actuators in gas compressor stations must operate under constant vibration.*

## Benefit from quality, versatility and service for years to come

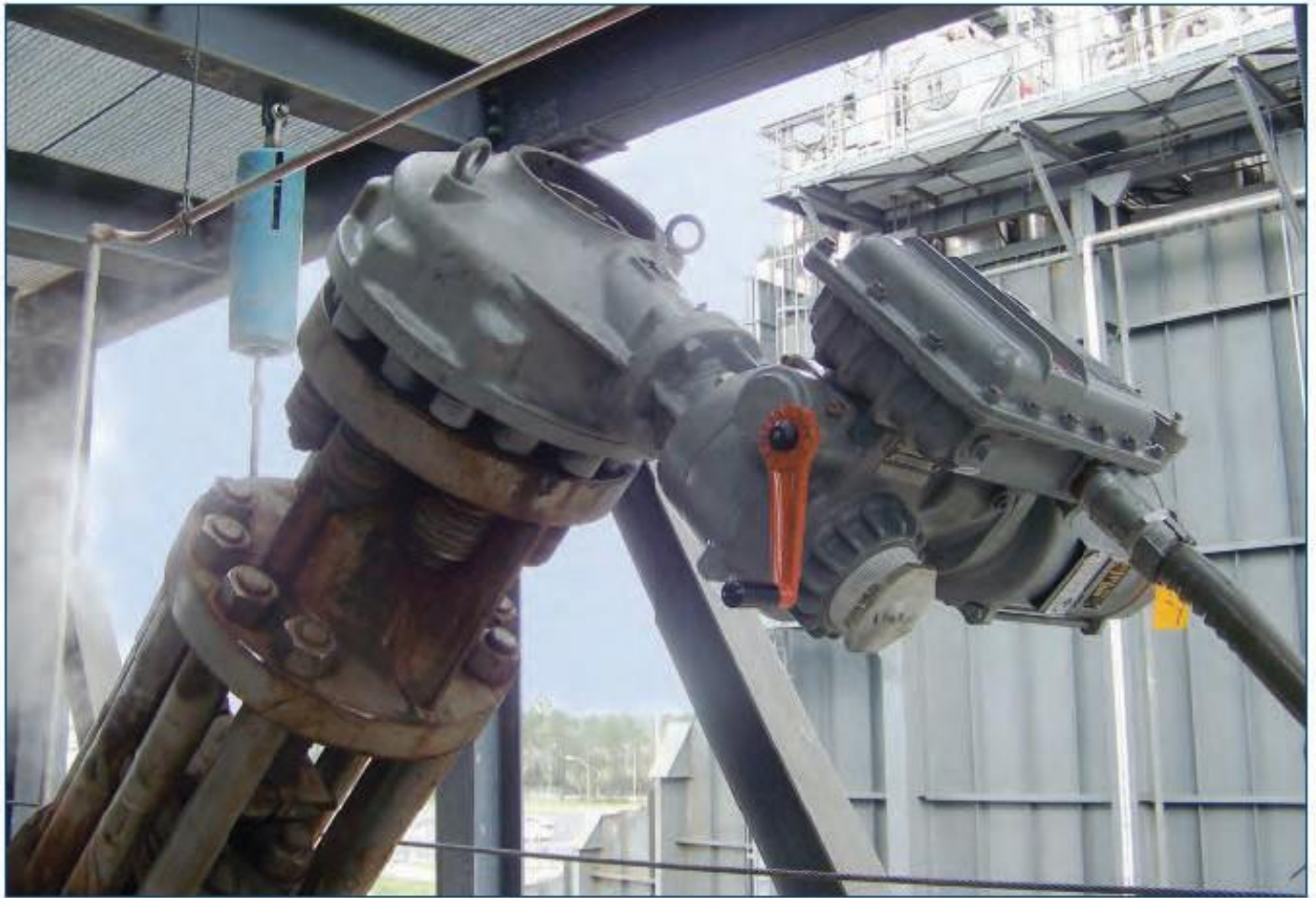

*M2CP/KBG bevel gear actuator in high-temperature steam service (1070°F; 577°C) at an electric power generation plant.*



*BETTIS AQUANAUGHT variant of the M2CP actuators can withstand extended submersion.*



*BETTIS AQUANAUGHT variant of the M2CP actuators can withstand extended vibration.*

# Selection Guide

## M2CP electric actuators fit a broad range of quarter-turn and multi-turn applications

M2CP actuators offer a wide range of frame sizes, horsepower ratings and output speeds to meet a variety of application requirements for voltage, torque, operating time, and valve-shaft diameter. Mounting dimensions are consistent with MSS SP-101, MSS SP-102, and ISO 5210.

Quarter-turn actuators are designed for ball, plug, and butterfly valves, as well as damper and louver drives. Models P, Q and R are direct-mounted for up to 2,500 foot pounds. Larger units use close-coupled worm gear actuators for up to 400,000 foot pounds.

Multi-turn actuators are designed for gate, globe, check, stop-check, and angle check valves, as well as sluice gates, weir gates, and multi-turn damper drives.

### Available Voltages

3 Phase, 60 Hz	208, 230, 380, 440, 460, 575, 690
3 Phase, 50 Hz	220, 380, 415, 460
1 Phase, 60 Hz	115, 208, 230
1 Phase, 50 Hz	115, 208, 230
DC	12, 24, 48, 125, 250

### M2CP Multi-Turn Actuators

Torque & Thrust Model	Torque		Thrust (force)		Maximum Acme Stem Diameter		RPM range		Mounting Base
	Ft-Lbs	Nm	Lbs.	KN	In.	mm	60 Hz	50 Hz	
1000	130	176	10,000	44	1.38	35.1	8-144	7-120	FA07,10/F07,10
2000	410	556	30,000	133	2.25	57.2	8-144	7-120	FA14,16/F14
3000	900	1,220	45,000	200	3.00	76.2	8-144	7-120	FA16/F16
3000A	900	1,220	45,000	200	3.50	88.9	8-144	7-120	FA16,19/F16
4000	1400	1,898	75,000	334	4.00	101.6	8-144	7-120	FA25/F25
5000	1900	2,576	90,000	400	3.50	88.9	8-96	7-120	FA30/F30
6000	5800	7,864	196,000	872	5.00	127.0	8-48	7-120	FA30,35/F30,35
7000	8,075	10,948	335,000	1,490	6.00	152.4	8-24	7-120	FA40/F40
8000	16,000	21,693	500,000	2,224	7.00	177.8	8-24	7-120	FA40/F40

### M2CP/KBG bevel gear

D/V2M	1,020	1,383	42,170	188	2.44	62.0	6-30	5-25	FA20/F20
D/V3M	1,275	1,729	64,745	288	2.83	71.9	6-18	5-15	FA25/F25
U/V3M	1,340	1,817	64,745	288	2.83	71.9	6-30	5-25	FA25/F25
U/V35M	1,670	2,264	78,680	350	3.35	85.1	6-30	5-25	FA30/F30
U/V4M	3,060	4,149	89,920	400	3.82	97.0	6-30	5-25	FA30/F30
S/V4M	3,835	5,200	89,920	400	3.82	97.0	6-30	5-25	FA30/F30
S/V5M	5,720	7,755	114,650	510	4.53	115.1	6-30	5-25	FA35/F35
S/V6M	9,580	12,989	519,300	2,310	5.12	130.0	6-10	5-8	FA40/F40
S/V7M	12,910	17,504	562,000	2,500	5.71	145.0	6	5	FA48/F48
S/V8M	13,680	18,548	562,000	2,500	5.71	145.0	6	5	FA48/F48

### M2CP/KBG heavy-duty bevel gear

D/V2HM	1,020	1,383	242,794	1,080	2.56	65.0	6-24	5-20	FA25/F25
U/V2HM	2,015	2,732	242,794	1,080	2.56	65.0	6-24	5-20	FA25/F25
U/V3HM	2,550	3,457	384,423	1,710	3.15	80.0	6-24	5-20	FA30/F30
S/V3HM	3,320	4,501	384,423	1,710	3.15	80.0	6-24	5-20	FA30/F30
S/V35HM	5,165	7,003	550,782	2,450	3.74	95.0	6-24	5-20	FA35/F35
S/V4HM	7,225	9,796	651,946	2,900	4.33	110.0	6-24	5-20	FA35/F35
S/V5HM	10,500	14,236	786,831	3,500	5.12	130.0	6-24	5-20	FA40/F40
S/V6HM	11,300	15,321	1,056,602	4,700	5.91	150.1	6-8	5-7	FA48/F48

## M2CP Multi-Turn Actuators

Model	Torque		Maximum Acme Stem Diameter		Operating Time (Seconds)		Mounting Base
	Ft-Lbs	Nm	In.	mm	60 Hz	50 Hz	
P	400	542	1.13	28.7	15-90	18-108	FA07, 10/F07, 10
Q	1000	1,356	2.00	50.8	5-120	6-144	FA12/F12
R	2500	3,390	3.25	82.6	15-360	18-432	FA16/F16
M/MG02	2,500	3,390	3.25	82.6	10-360	12-432	FA16/F16
M/MG03A	5,000	6,780	4.00	101.6	10-600	12-720	FA30/F30
M/MG03B	7,500	10,170	5.00	127.0	10-600	12-720	FA30/F30
M/MG05	15,000	20,340	6.00	152.4	15-900	18-1080	FA35/F35
W/MG05	30,000	40,680	7.00	177.8	15-900	18-1080	FA40/F40
W/MG07	70,000	94,920	8.00	203.2	45-900	54-1080	FA48/F48

## M2CP/KWG Worm Gear

D/KWG-02M	1,750	2,373	2.25	57.2	15-120	18-144	FA16/F16
D/KWG-03M	3,150	4,271	2.75	69.9	15-180	18-216	FA16/F16
D/KWG-03-1SM	3,150	4,271	2.75	69.9	240-360	288-432	FA16/F16
D/KWG-04M	4,500	6,102	3.31	84.2	15-180	18-216	FA25/F25
U/KWG-04M	5,650	7,661	3.31	84.2	15-180	18-216	FA25/F25
D/KWG-04-1SM	5,650	7,661	3.31	84.2	240-600	288-720	FA25/F25
U/KWG-05M	9,720	13,180	4.13	104.8	15-180	18-216	FA30/F30
S/KWG-05M	10,900	14,780	4.13	104.8	15-180	18-216	FA30/F30
D/KWG-05-1SM	10,960	14,862	4.13	104.8	240-480	288-576	FA30/F30
U/KWG-05-1SM	10,960	14,862	4.13	104.8	600	720	FA30/F30
S/KWG-06M	19,600	26,578	4.94	125.4	15-60	18-72	FA35/F35
D/KWG-06-1SM	15,170	20,571	4.94	125.4	90-240	108-288	FA35/F36
U/KWG-06-1SM	19,600	26,578	4.94	125.4	90-600	108-720	FA35/F37
S/KWG-07M	37,680	51,094	6.44	163.5	15-60	18-72	FA40/F40
U/KWG-07-1SM	33,800	45,833	6.44	163.5	90-600	108-720	FA40/F40
S/KWG-07-1M	37,680	51,094	6.44	163.5	45-600	54-720	FA40/F40
U/KWG-08-1SM	35,270	47,826	8.00	203.2	180	216	FA48/F48
S/KWG-08-1SM	78,180	106,012	8.00	203.2	60-480	72-576	FA48/F48
U/KWG-08-1SDM	78,180	106,012	8.00	203.2	360	432	FA48/F48
S/KWG-09-1SDM	123,150	166,991	9.50	241.3	90-480	108-576	FA48/F48
S/KWG-10-1SDM	184,350	249,979	11.25	285.8	120-600	144-720	FA60/F60
S/KWG-11-1SDM	272,800	369,917	12.75	323.9	180-600	216-720	FA60/F60

## Ratings and Certifications

### NEMA 4, 4X, 6, 7 & 9

- Standard Temperature Rating: -30°C to +70°C
- Optional Low-Temperature Rating: -50°C to +60°C
- Optional IP68 Submersible Service: 20 ft. (6m) 72 hrs.

### FM Factory Mutual (USA)

- Classes I, II, III Division 1,
- Groups B, C, D, E, F & G T4 130°C

### CSA (Canada)

- Classes I, II, III Division 1,
- Groups C, D, E, F & G T4 130°C

### ATEX II 2 GD (Europe)

- Ex d IIB T4 Gb
- Ex tb IIIC T135°C Db IP66
- Tamb -20°C to +60°C
- (Optional Tamb -40°C to +60°C)

### ANZEx Australia/New Zealand

- Ex tb IIIC T4 T135°C Db
- -20°C ≤ Ta ≤ +60°C

### GOST (Russia)

- 1 Ex d IIB T4/H2
- -40°C to +70°C
- Optional -60°C to +70°C
- IP68

### IECEX Int'l Electrotechnical Commission

- Ex tb IIIC T4 T135°C Db
- -20°C ≤ Ta ≤ +60°C

# M2CP electric actuators fit a broad range of quarter-turn and multi-turn

- ① **Motor** options include most voltages of single-phase or three-phase alternating current and direct current. Built-in thermal protection is standard.
- ② **Motor gear** selections allow speed and torque output combinations.
- ③ **Handwheel gear set** allows users to limit the rim pull required to operate valve manually regardless of torque required.
- ④ **Transformer** is fully encapsulated and epoxy impregnated.
- ⑤ **Reversing contactor** is DIN rail mounted for quick maintenance.
- ⑥ **Power module (PWR)** provides transformer primary fuses and terminal strip for motor voltage.
- ⑦ **Terminal board module (TBM)** provides connection points for user wiring and transformer secondary fuses.
- ⑧ **Overload relay option** senses over current for motor thermal protection.
- ⑨ **Intermediate switch module (ISM)** options include Controlinc™ digital network, Futronic™ modulating controls, interposing relays, and intermediate limit switches.
- ⑩ **Limit switch module (LSM)** allows combinations of position limit switches, torque switches, push buttons, pilot lights, and selector switch.
- ⑪ **Light emitting diodes (LEDs)** add reliability and operating life.
- ⑫ **Torque switch** protects valve and actuator in both open and closed directions.

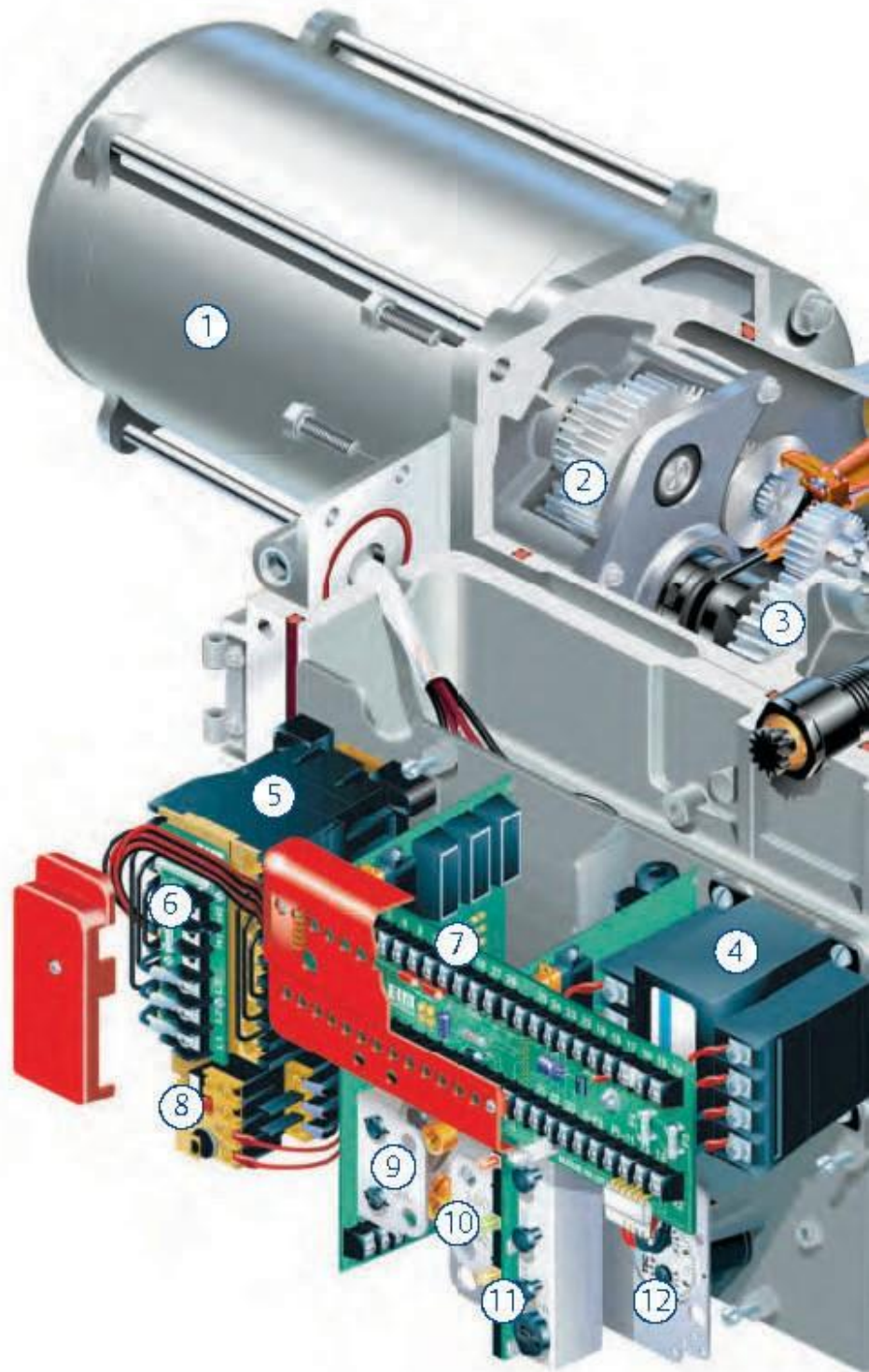

## Digital Control Packages Provide the Latest Networking Capabilities

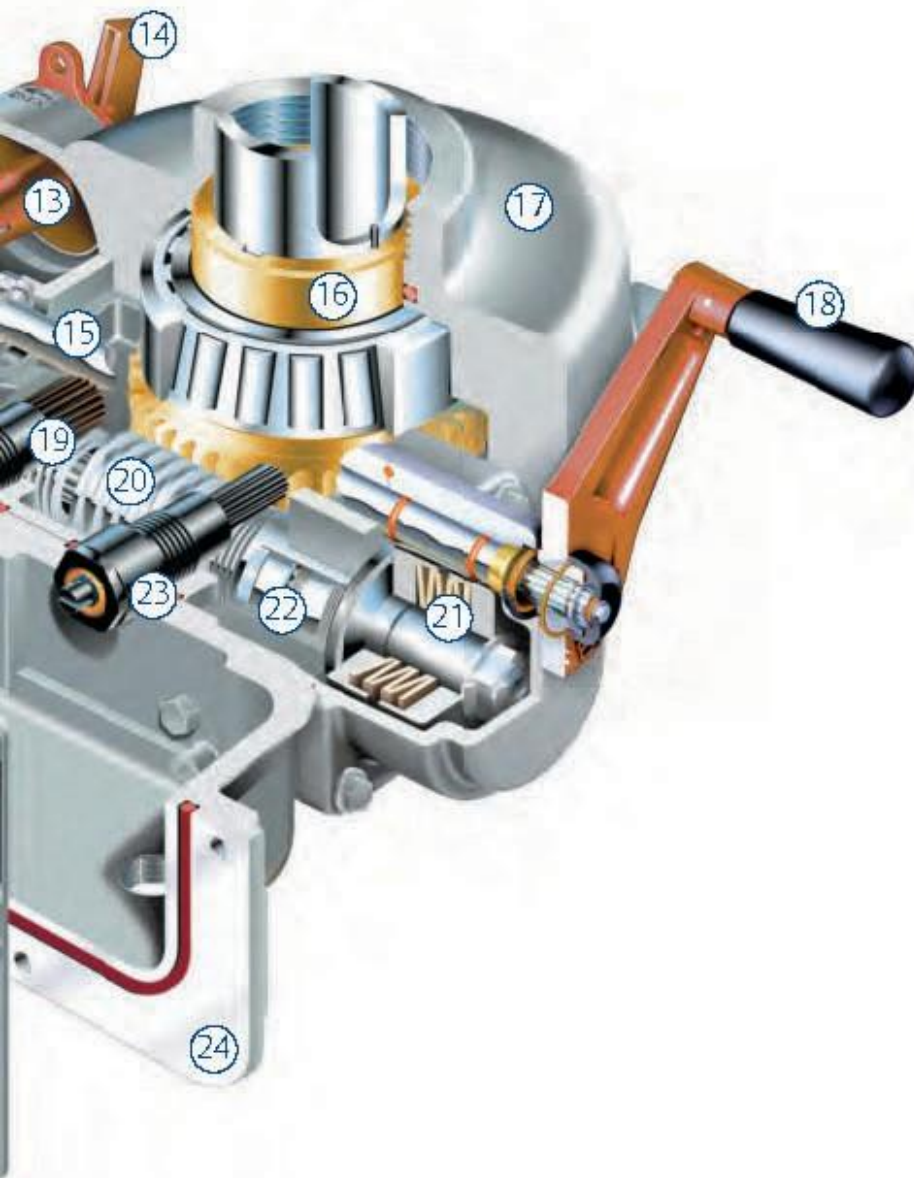

- ⑬ **Power shift clutch** requires minimal force to operate even when valve is tightly seated.
- ⑭ **Clutch handle** can be padlocked in either hand or motor position to prevent unauthorized use.
- ⑮ **Handwheel shaft** is supported by bearings and splined at both ends to eliminate keys.
- ⑯ **Drive sleeve** consists of a bronze worm gear and drive sleeve supported by tapered roller bearings to maximize radial and thrust-load support.
- ⑰ **Main housing** is ductile iron to provide maximum strength and durability.
- ⑱ **Fold-up handle** for manual valve operation in emergency or power outage has compact profile to stay out of the way until needed.
- ⑲ **Geared limit drive assembly** always remains in sync with valve position. No batteries required.
- ⑳ **Worm shaft** is heat-treated alloy steel.
- ㉑ **Torque springs** accurately sense torque independent of electronics and regardless of voltage fluctuations.
- ㉒ **Roller bearings** support the worm shaft.
- ㉓ **Torque limit assembly** receives rotary mechanical feedback from torque springs directly through main worm shaft. Torque switch is active in both electric and handwheel operation.
- ㉔ **Electrical compartment enclosure** has hinged cover, O-ring seals, stainless steel hardware, and multiple conduit entries.

# Design Features

## Motors and Spur Gears

BETTIS motors employ a minimum number of mounting configurations to maximize interchangeability. The motor and spur gear set form a modular unit that is mounted with only eight accessible fasteners.



### Motor gear assembly

- Wide range of motor-reduction spur gear selections offers multiple speed and torque output combinations.
- Field modification of torque and RPM outputs is easily accomplished.



### Motor gears

- Alloy steel motor gears are spline mounted for strength and ease of installation.
- Gear sets are interchangeable.
- Assembled in single- or double-reduction ratios as required for actuating time.

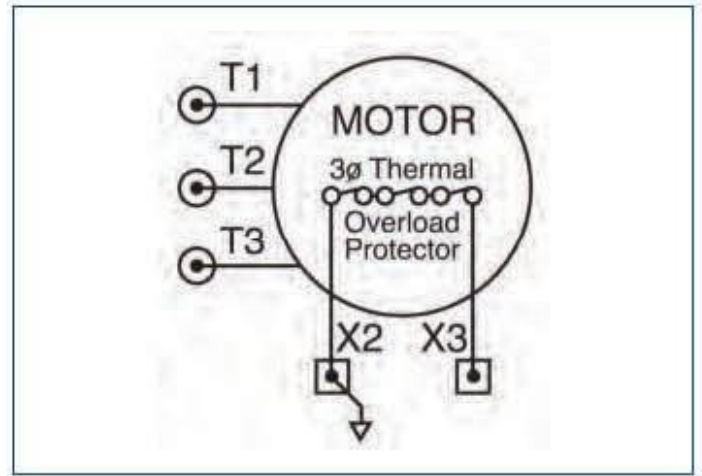

### Thermal overload protection

- Thermal contacts sense winding temperature and break the control circuit before damage occurs.
- Standard motors, supplied with thermal overload protection may be disabled for emergency shutdown installations.

**CAUTION: disabling overload protection can undermine explosion-proof capabilities and may violate hazardous code certifications.**

## Handwheel Override / Clutch Mechanism

M2CP actuators include an auxiliary clutch handle for emergency use. The clutch operates on the low torque side of the worm and worm gear drive train, and requires minimal force to operate. The valve, gate or damper is never disconnected from the self-locking worm gear.



### Clutch lever assembly

- Lever shifts position of the splined clutch spool so power drive can be engaged by either motor or hand wheel.
- Assembly requires no adjustment and mounts with just three screws.
- Lever can be padlocked in "manual" mode for safe maintenance, or in "motor" mode to prevent tampering. Motor preference is standard.
- Common to all M2CP model sizes.

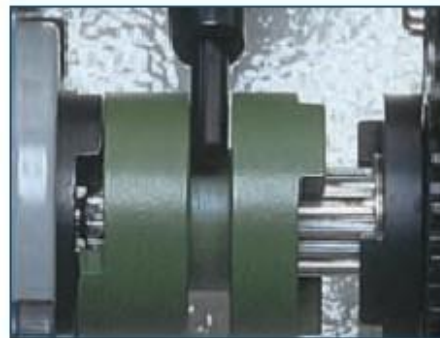

### Clutch spool

- Steel clutch spool makes simultaneous engagement of motor and handwheel impossible.
- Power from motor cannot be transmitted to manual lever.
- Drive connection to worm shaft is by sliding spline.
- Fused motor does not prevent handwheel operation.



### Padlockable clutch handle

- For added safety, clutch handle can be padlocked in either manual or motor position to prevent tampering or unauthorized use.

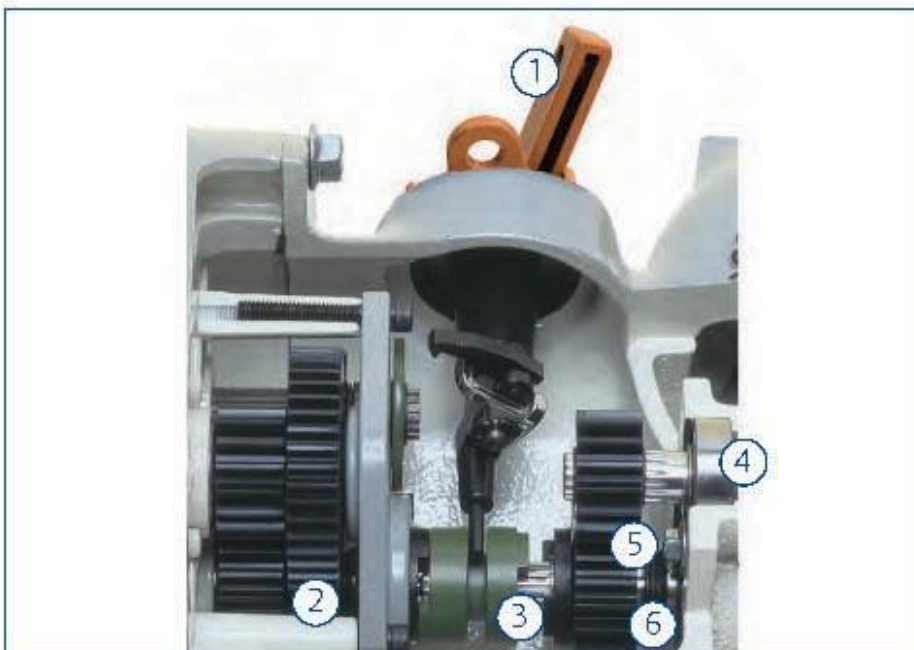

(Above: clutch handle detail)

### Clutch assembly

1. Clutch handle (padlockable)
2. Motor spur gears (alloy steel)
3. Clutch spool
4. Handwheel shaft
5. Handwheel gears
6. Clutch shaft assembly

# Main Gears

The main drive train of the M2CP actuator incorporates a heat-treated alloy steel worm, as well as a cast-bronze worm gear drive sleeve, supported by tapered roller bearings to maximize thrust load support.



## Worm and clutch assembly

- Torque is received through clutch shaft from motor and first stage motor spur gear set.
- Torque springs are easily accessible for field changeover to raise or lower torque range.
- Alloy steel, heat-treated worm is bearing supported.

## Clutch shaft splined connection

- In operation, the clutch shaft is "fixed" by splined connection for accurate geared limit drive calibration.
- Worm moves axially on its splined connection in either direction against the torque spring assembly for torque sensing.
- Input from motor and motor gears is transmitted through the worm to the bronze worm gear drive sleeve.





### Limit switch gearbox

- A limit switch gearbox is mechanically connected to actuator worm through the geared limit-drive assembly.
- The limit switch gearbox remains in sync with valve position at all times, whether driven by motor or handwheel, even under lost power conditions.
- Both the torque and limit switches maintain settings in all conditions without relying on battery backup.



### Splined drive bushing

- Quarter-turn actuators offer a bottom-entry splined steel bushing design to simplify mounting on valves.
- Splines provide high-strength, multiple-position connection to the keyed valve shaft, improving accuracy of seat calibration and allowing for multiple mounting positions not possible with bored and keywayed drive sleeves.
- Cast bronze worm gear drive sleeves are mounted in high-quality tapered roller bearings to maximize thrust load support.



### Torque switch

- A limit switch gearbox is mechanically connected to actuator worm through the geared limit-drive assembly.
- The limit switch gearbox remains in sync with valve position at all times, whether driven by motor or handwheel, even under lost power conditions.
- Both the torque and limit switches maintain settings in all conditions without relying on battery backup.



*Drive assembly cutaway view*

# M2CP Modular Control Package

## Unsurpassed quality, reliability, flexibility and ease of use

BETTIS changed the name of the Series 2000 actuator to M2CP to emphasize the advanced modular control package (which is also known as M2CP) that serves each actuator. The M2CP module is designed to provide years of flexible, reliable, and cost-effective valve automation. Servicing and upgrading are quick and easy. The entire package or any component can be removed and replaced in minutes—ensuring that the M2CP actuator is always ready to accommodate future control technologies.

BETTIS also continues to support the previous generation of technology, the MCP, which was the industry's first modular control package. (Some MCP units are still in service after more than 30 years)

### M2CP offers ease of service and maintenance.

The entire electronic control package of the user-friendly M2CP can be removed, assembled, disassembled, and replaced using only a standard screwdriver. As a result, field service can be performed quickly and easily with fewer mistakes. The module can also be used for non-integral applications with remote-located motor starters.

### Reversing contactor

- Reversing contactor/power module is DIN rail mounted for snap-in/ snap-out convenience. Captive stainless screws secure module from vibration.
- Reversing contactor is mechanically and electrically interlocked.
- Power module offers easy access to transformer primary fuses and separate high-voltage terminal strip for incoming power leads.
- Optional phase sentry provides single-phase protection and prevents incorrect rotation.

### Terminal board module

- Each transformer secondary is individually fused and grounded on the terminal board module for easy accessibility.
- Transient power surge suppressors are located throughout the M2CP module to protect electrical components.
- Terminal board module provides convenient access to 48 terminal points, analog and digital signal inputs/ outputs, and control voltage.

### Integral control panel

- High-intensity LED panel lights offer lifetime service, much longer than conventional incandescent bulbs.
- Triple O-ring sealed, stainless steel push buttons ensure long-term integrity against leaks and corrosion.
- 3-position selector switch is available with padlockable or key switch.

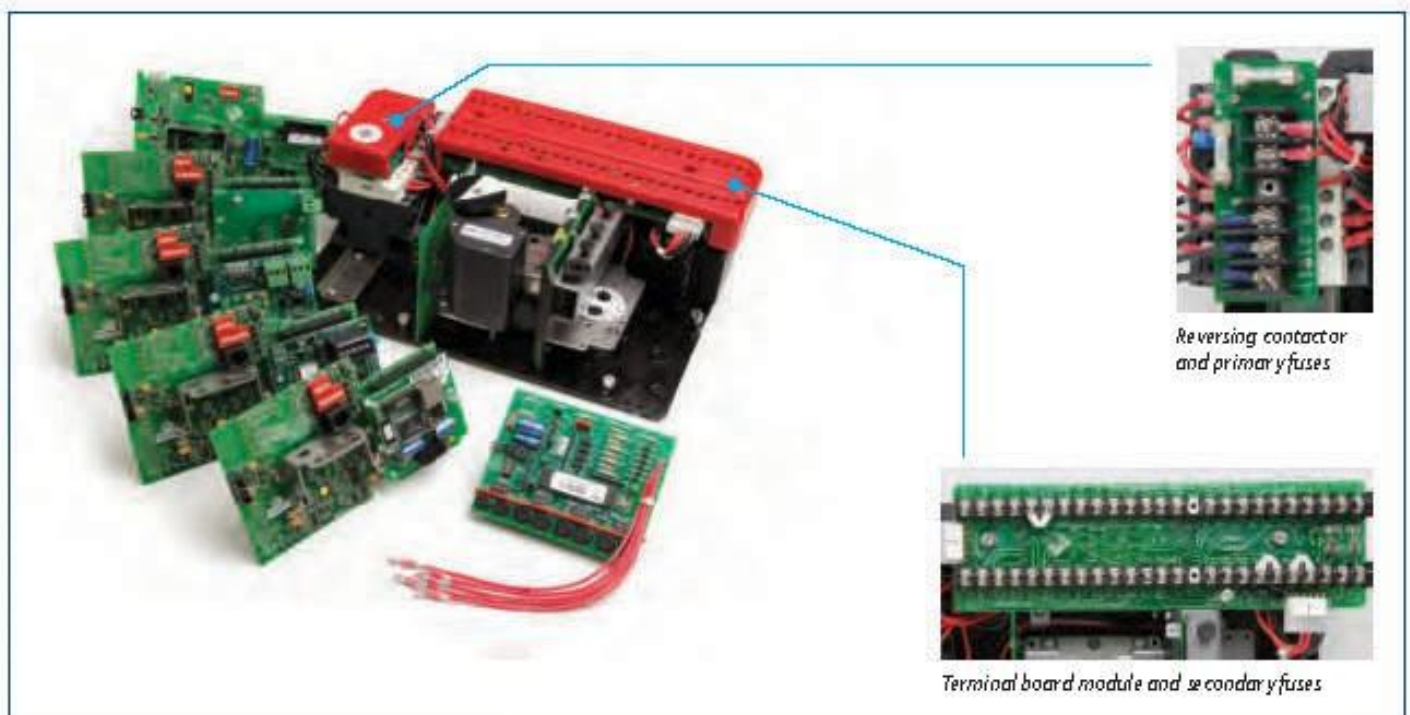

Modular control package with optional control boards



### Mechanical Dial Position Indicator (MDPI)

- Indicator is driven by a high-precision set of reduction gears. On multi-turn applications, visual indication of valve position from 0-100% is provided.
- Dial is mechanically in sync with valve position at all times regardless of motor/handwheel operation or availability of power.
- An optional combination mechanical/electronic position indicator is also available (shown above).
- Tempered, explosion proof glass display window never becomes clouded or discolored.

### Futronic™ analog modulating control module

- Futronic™ modulating controls are capable of handling both position and process control elements via industry standard 4-20 mA signal.
- Futronic II position control uses 1- or 3-phase power.
- Futronic III process control uses 1-phase power, DC motor, solid state starter.
- Futronic IV process control uses solid-state reversing starter, 3-phase power, and AC motor.
- Futronic VIII supports variable-frequency control.



### Circuit breaker module

- The circuit breaker/disconnect switch interrupts the circuit between actuator and current source, removing all power to ensure safety during servicing or field maintenance.
- Protects motor control apparatus and motor against over-current due to short circuits or grounds.
- Several disconnect devices are available mounted in electrical compartment or in separate control modules that can be close coupled connected to actuator or bracket-mounted to a wall, panel, rack, or pipe.



# ControlInc™ Network Control

## M2CP easily adapts to the latest digital network technology

The M2CP delivers the dynamic combination of robust mechanical actuators plus the latest digital control technology.

An optional ControlInc™ communication module with onboard microprocessors can equip the M2CP to achieve full digital network functionality. BETTIS does not employ proprietary protocols. Standard protocols supported include:

- Modbus RTU
- FOUNDATION™ fieldbus
- Profibus DP with Redcom redundancy
- DeviceNet
- Ethernet

ControlInc™ includes traditional open/close or precise set point commands as well as complex digital control network monitoring and response systems. Digital communication reduces wiring costs using small diameter communication cable for command and monitoring of actuator performance and valve parameters.

### Standard ControlInc™ features and benefits

- Microprocessor-based controller is integral to each actuator.
- Can be used with all types of valves and processes.
- Removal or failure of the module does not affect local push button control.
- Installation and setup is quick and easy.
- Easy to use and maintain.
- No proprietary protocols required. All communication flows unrestricted via industry-standard protocols, so the Host can communicate directly to each actuator or to BETTIS's optional network master stations using Modbus RTU.
- Backwards compatible for more than 20 years of BETTIS actuators.
- Distributed control capability reduces central computing equipment costs.
- "Learns" characteristics of valves and adapts accordingly.
- Auto-calibration eliminates need for user adjustments.
- Can reduce wiring costs by up to 60 percent.
- Can acquire data and control other devices at no additional cost.
- Compatible with existing Host equipment (PLC, DCS, SCADA).
- Real time data acquisition and diagnostics with alarms to reduce downtime, safety hazards, process interruptions, and lost production.
- Single, standardized model reduces spare parts inventory and availability.

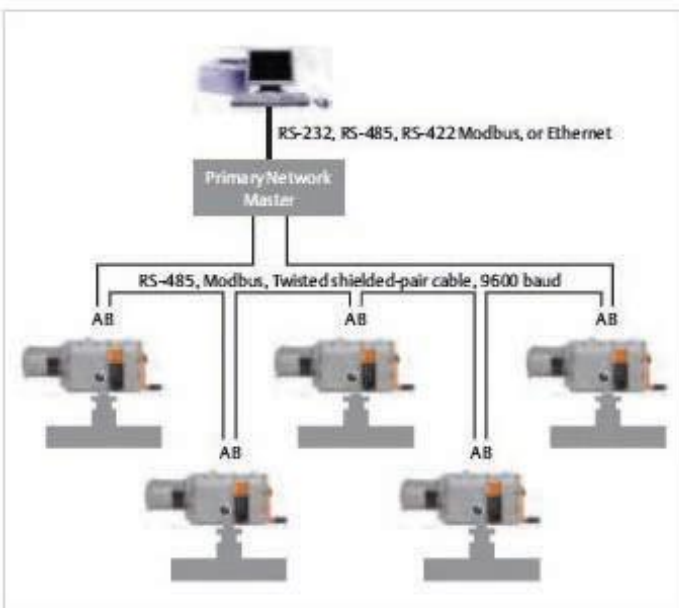

Serial E-Net Redundant Ring Topology

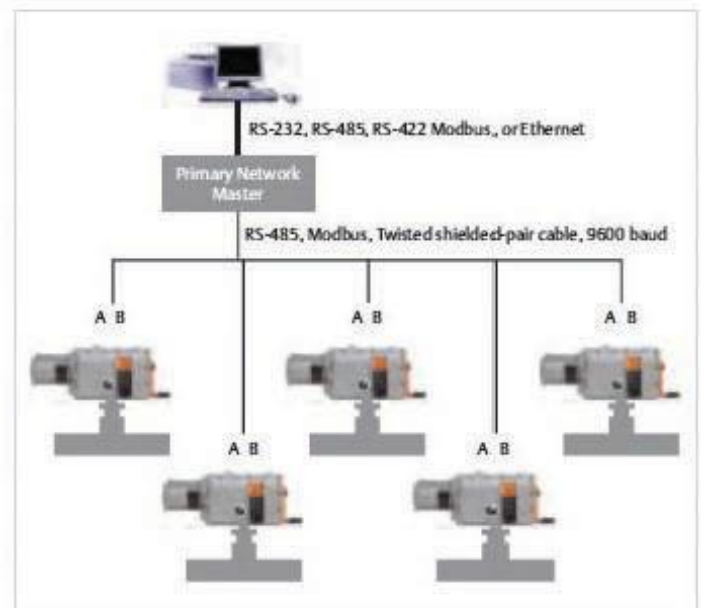

Multi-drop Bus Topology

# Controlinc™ Modbus RTU supports up to 250 valves and other devices over a 200-mile range

## Network master features and benefits

- Offers network management and data concentration, offloading tasks from Host to enhance overall system performance and minimize software/hardware configuration costs.
- Monitors and records orderly cycle of data transfers to and from connected actuators.
- Achieves data concentration for Host using a common database for all actuators. Host need only communicate with one "slave" device (network master) for all data transfers to and from field.
- Provides Isolation and transient protection for Host.
- Input cabling from Host can be RS-232, -485, -422, or Ethernet.
- Supports baud rates up to 115,200 baud to host.
- Optional LCD display/keypad or touch screen allows users to control network and receive status and alarms of each actuator on the network.
- M250 supports up to 250 actuators and other devices.
- M124 supports up to 124 actuators and other devices.
- Mounting options /M250: 19-Inch rack or desktop mountable.
- Mounting options /M124: 19-Inch rack, desktop, or NEMA 4X enclosure.



Easy to install, Controlinc™ control modules offer a range of possibilities. (Shown: M250 Master Station)

## Here's how Controlinc™ pays off long-term:

### Cost savings

- Reduced cable costs.
- Host system off-loads.
- Reduced downtime and service requirements.

### Increased efficiency and reliability

- Ability to maintain local push button control.
- Reduced demands on Host system.
- Mechanical geared limit and torque switches maintain valve/actuator position sensing in a power failure without power backup.

### Expanded capabilities and flexibility

- Modbus RTU communications operates at 19.2 Kbaud or 9.6 Kbaud with 250 devices over 200 miles.
- Plug-In adaptors support a range of network topologies, including single and redundant bus and ring networks.



M250 Network Master with optional LCD display & touch screen



M124 Network Master with optional LCD display & keypad

## VAL TECHNOLOGY & ENGINEERING SDN. BHD.

No. 1, Lorong Teras Jaya 3, Taman Perindustrian Teras Jaya,  
13400 Butterworth, Penang, Malaysia.

Tel: +604-333 4119 (Hunting) Fax: +604-333 4120

Email: [sales@valtech.com.my](mailto:sales@valtech.com.my)

URL: [www.valtech.com.my](http://www.valtech.com.my)