

2000LP Multi-turn Pneumatic Actuators

Low pressure air/gas power for gate and large bore quarter-turn valves



Designed to handle every low pressure valve control need in your system

The EIM 2000LP pneumatic actuator from Emerson is a multi-turn air driven actuator that is perfect for applications using linear, rising stem or rotating stem valves. Developed for operation in any application where reliable electricity is not available, the 2000LP operates valves using 40-100 psi (2.8 – 6.9 bar) air or other suitable gases as its power source.

The robust actuator is based on the proven EIM Series 2000 platform, with more than a half-century of outstanding field performance around the globe. It has the most durable internal components in the industry, assuring long-term reliability.

Widely used throughout all industries since the 1970's, the 2000LP is well suited for any industrial or pipeline application where compact design, simple manual over-ride, travel limits, and torque protection are desired.

The 2000LP can handle virtually any local or remote control system requirement. A variety of standard single or double acting pneumatic and electric remote control configurations are available with optional electric limit switches.

The actuator, as an independent unit, is capable of producing up to 900 lb/ft (1,220 Nm) of torque and 45,000 lb (200.18 kN) of thrust. Torque outputs up to 135,000 lb/ft (183,036 Nm) and thrust outputs up to 900,000 lbs (4,003.6 kN) can be attained through the addition of bevel or worm gearboxes.

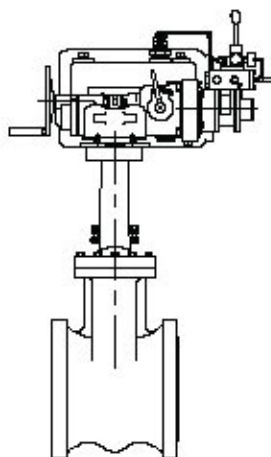

2000LP is distinctive

- Adaptable to quarter-turn or multi-turn applications
- Directly mounting on rising stem valves
- Manual override, travel limits, and torque protection are standard
- Highly visible position indication dial available when using electric control pack
- Usable with bevel or worm gears
- Local/remote controls
- Padlockable clutch handle in either hand or motor position
- Handwheel operation in power loss or emergency operation
- Corrosion resistant valving
- MSS or ISO mounting flanges

2000LP offers numerous benefits

- More economical than linear piston actuators
- Provides reliable emergency shutdown service
- Can be equipped for operation with pressurized air, nitrogen or natural gas
- Hundreds of torque/thrust/speed combinations available
- Compact design for space saving installations
- Mechanically locks valve in place when idle
- Eliminates hydraulic manual override



2000LP Features

- Built using the same rugged design of the EIM Series 2000 electric actuator

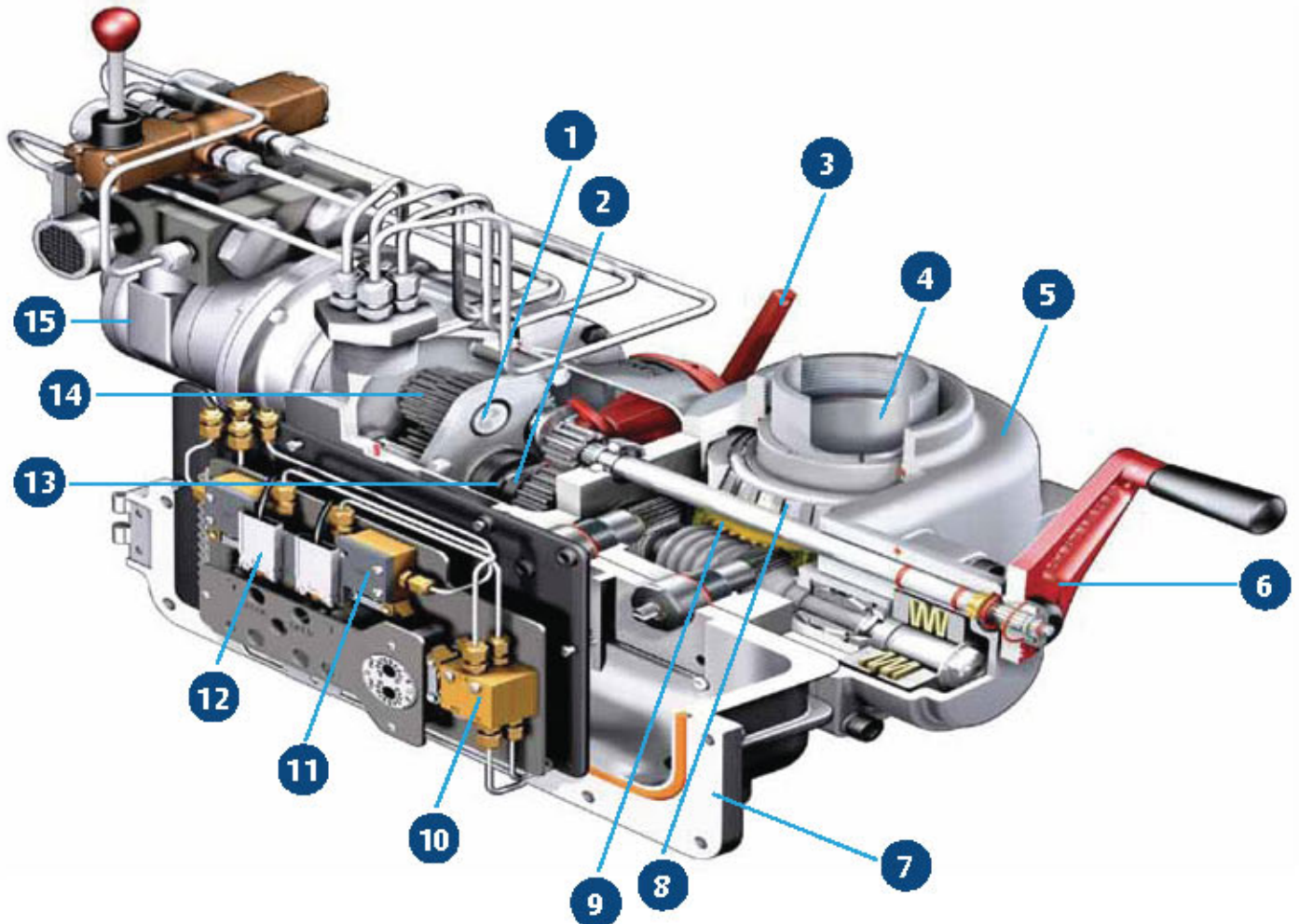

Rugged Features are integral to the 2000LP design

- | | |
|--|---|
| 1 Bearing supported shafts (no bushings) | 9 Permanently self-locking worm and wheel |
| 2 Automatic motor priority | 10 Torque protection (internal and standard) |
| 3 Low dedutch force | 11 Travel limits (internal and standard) |
| 4 Valve stem never disengages from the drive sleeve | 12 Position indication (optional) |
| 5 Ductile iron housing | 13 Low torque side declutching |
| 6 Low rim-pull (80 lbs/350N maximum) | 14 Alloy steel motor gear selections allow numerous speed and torque output combinations |
| 7 Hinged cover, O-ring sealed controls enclosure | 15 Low consumption pneumatic vane air motor |
| 8 Tapered top and bottom roller bearings | |

2000LP Control details

- 2000LP control power supply range 10 to 100 psi (0.7 to 6.9 bar)
- Motor rating 40 to 100 psi (2.8 to 6.9 bar)
- Local control function utilizing manually-operated selector valve
- Meets ingress protection classification IP66

Control options

- Optional electrical position indication switches available. Switch certification rating: II 2g Ex d IIc T6; IID Ex tDA21 IP66 T80C
- Optional electric remote operation available. Solenoid certification rating: Class I, Div I, Grp C&D; Class II Div I, Grp E, F, G. ATEX certified solenoids available on request.
- Custom control schemes available

